



PIPECO



Manufacturer of :

- GRP Sectional Water Tank
- Hot Dipped Galvanized Steel Sectional Water Tank
- Pressed Stainless Steel Sectional Water Tank



Malaysia, Melaka



Taipei, Taiwan



France / Romania



**King Abdullah Financial District (KAJD)
Riyadh, Saudi Arabia**



Jakarta, Indonesia

INTRODUCTION

PIPECO was formed in 1984 as an engineering hardware company and ventured into sectional panel water tank business in 1989. To date, we have 28 years experience manufacturing water tanks. PIPECO has provided water storage solutions to many companies in world, supplying both pressed steel and GRP (Glass Reinforced Plastic) sectional water tanks. PIPECO is a global company, which already has partnerships in various countries, including: Malaysia, Singapore, south East Asia, Middle East countries such as U.A.E, Qatar, Saudi Arabia, Oman, and European countries such as France, Belgium and Australia.

The production facilities are housed in Port Klang, Malaysia, with an area of 20,000m². Our facilities have the capacities to annually produce 300,000 GRP tank panels and 50,000 pressed steel tank panels. This allows PIPECO to fulfill customer's expectations with competitive pricing, prompt delivery and consistent, high quality products.

PIPECO strives to provide the best quality product to the customer. We have a well established quality management system. Since 2003, PIPECO has been accredited the ISO 9001:2000 standard. This ensures that the tank panel and accessories are produced under the most stringent quality audit and meet the required structural and durability performance. By using advanced automated production facilities and employing a team of highly skilled production staff, PIPECO is able to ensure that the tank panel and accessories produced conforms to a consistent high quality standard.

In addition, PIPECO values customer satisfaction and expectations. Therefore, PIPECO communicates with the clients throughout all stages of the tank provision; from the design, supply, installation and the final commissioning stage. This ensures that the specific requirements of the customers are met.

Production Facilities



Robotic Welding Machine

Production Facilities



Laser Cutting Machine



SMC Moulding Machines

GRP SECTIONAL WATER TANK

GRP TANK @ MELAKA, MALAYSIA

PROJECT : KONICA

TANK SIZE : [125m x 12m x 3m(H)] + [20m x 15m x 3m(H)]

CAPACITY : 5400m³ / 1.2 million gallons of water



GENERAL SPECIFICATIONS

Standard :

Singapore Standard SS245: 1995 similar to British Standard BS 7491 Part 3:1994 and BS EN 13280:2001

Materials :

Sheet Moulding Compound (SMC) consists of :
Resin - Isophthalic unsaturated polyester resin conforming to BS 3532 specification
Fiber Glass - Low alkali fibre glass conforming to JIS R3411 to R3417 or BS 3396, BS 3496 and BS 3749 specifications

Manufacturing Process :

Hot pressed SMC compression moulding

Tank Structural Support :

Tank Structural Support:
Tie-rod System : External: Hot Dipped Galvanised Steel
Internal: SS304 Tie-rod, Optional SS316
Roof Support : PVC/ABS pipes with GRP roof panel stiffener
External Braced System : External: Hot Dipped Galvanised Steel
Internal: None (metal free inside, non-partitioned tank only)
Roof Support : PVC Poles with GRP roof panel stiffener

Sealant :

Non toxic PVC foam/EPDM Rubber

Bolt, Nuts, Washers :

External : Standard : Hot Dipped Galvanised Steel
Optional : SS 304/316

Internal : Standard : SS 304 (In-contact with water)
Optional : SS 316 (In-contact with water)

Roof : Standard : Hot Dipped Galvanised Steel
Optional : SS 304/316

Ladder :

External : Standard : Hot Dipped Galvanised Steel
Internal : Standard : PVC or Aluminium
: Optional : GRP or SS 304/316

Water Level Indicator :

Standard : Reverse Reading Pointer Mechanical Type (Cat & Mouse)
Optional : Direct Reading Clear Tube Type

Nozzle Panel :

Pipe nozzles not inclusive
Flat panels will be provided on request

*Note: Specification may vary according to client's requirement.

GRP PANEL DESIGN

BASE PANEL

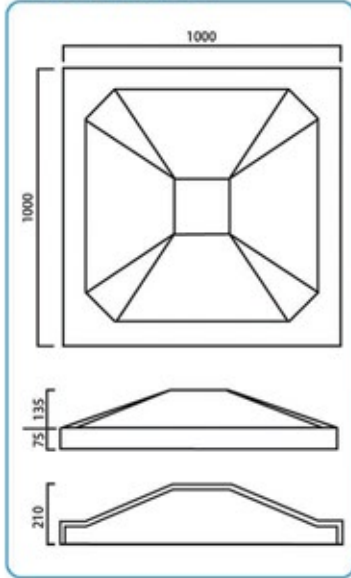

Base Panel 1m x 1m

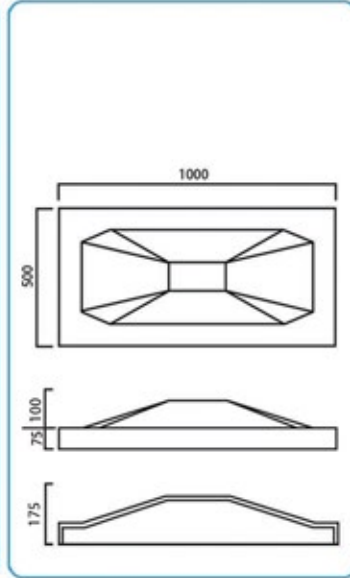

Base Panel 1m x 0.5m

TOP PANEL

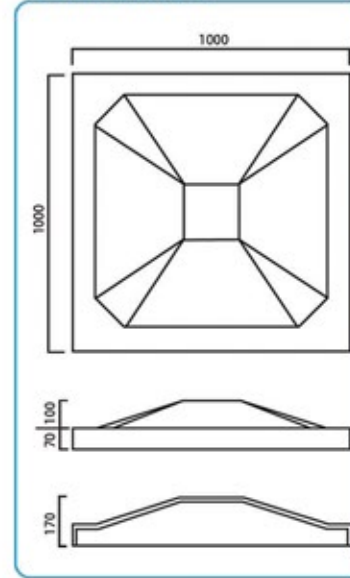

Top Panel 1m x 1m

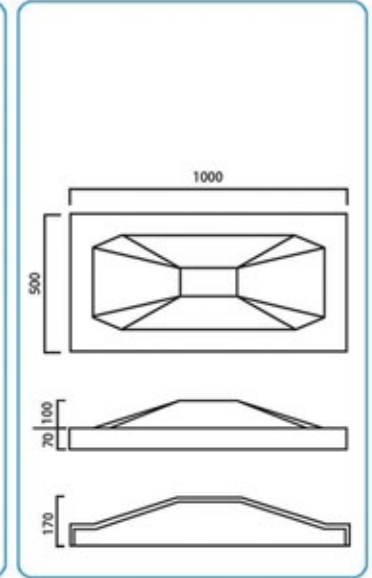

Top Panel 1m x 0.5m

SIDE PANEL

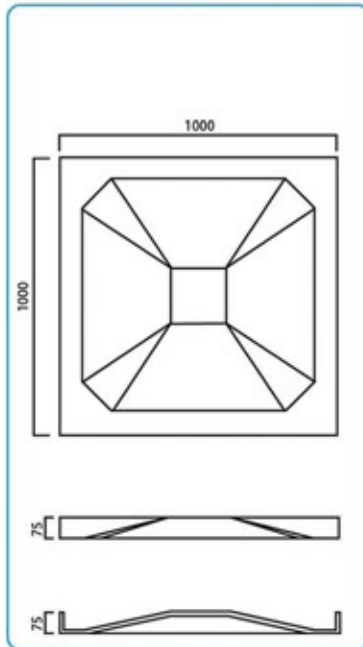

Side Panel 1m x 1m

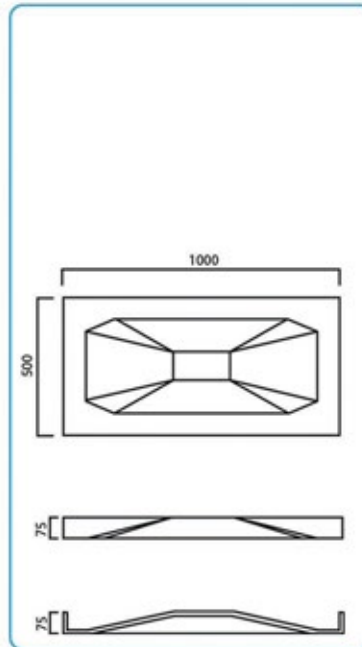

Side Panel 1m x 0.5m

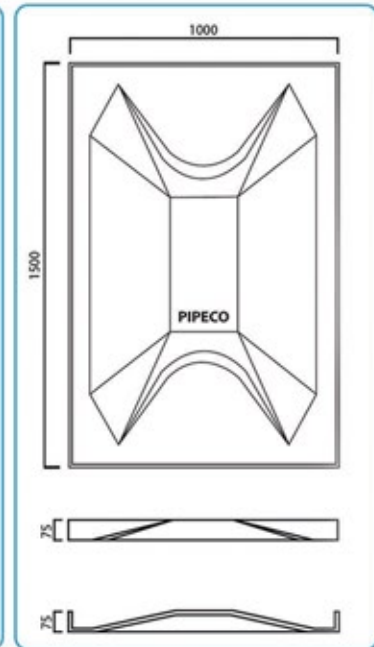

Side Panel 1m x 1.5m

Performance of Panels

| Characteristics | PIPECO GRP Tank Panel Performance | Acceptance Criteria (SS 245:1995 Specification) |
|--|--------------------------------------|--|
| Tensile Strength (MN/m ²) | 103 | >70 (min) |
| Bending Strength (MN/m ²) | 170 | > 100 (min) |
| Elastic Modulus in Bend (MN/m ²) | 13580 | > 6000 (min) |
| Glass Content (%) | 39 | > 25 (min) |
| Barcol Hardness | 59 | >30 (min) |
| Water Absorption (%) | 0.05 | 1.0 (max) |

NOZZLE / FLAT PANEL

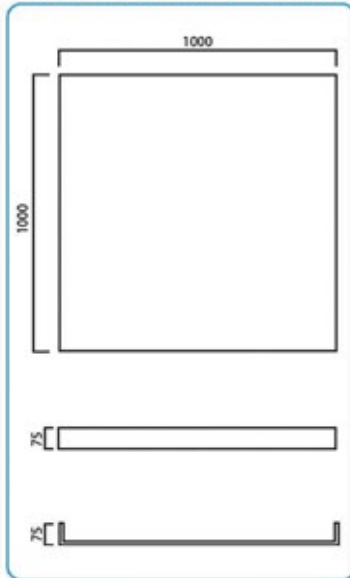

Nozzle/Flat Panel 1m x 1m

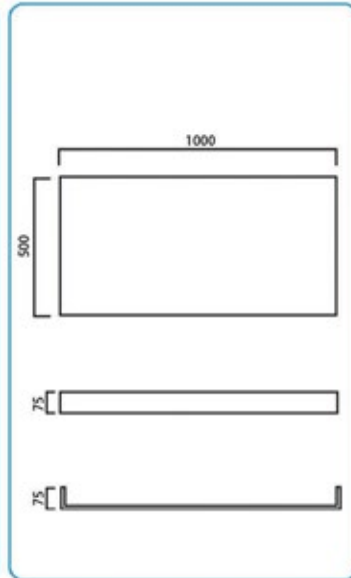

Nozzle/Flat Panel 1m x 0.5m

MANHOLE

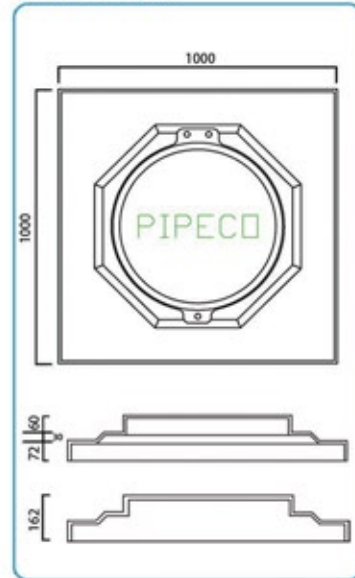

Manhole 1m x 1m

PRE-INSULATED PANEL

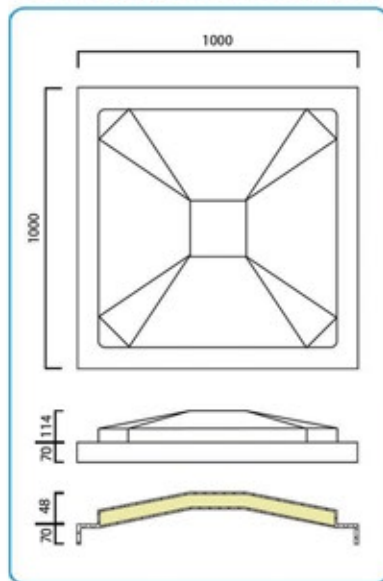

Top Panel 1m x 1m

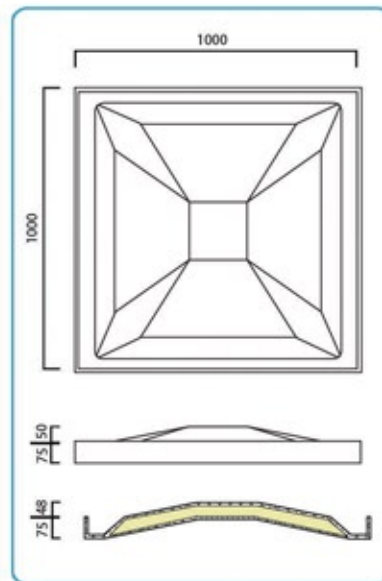

Side Panel 1m x 1m

By encapsulating a 25mm ~ 50mm layer of rigid polyurethane foam, PIPECO pre-insulated panel could maintain the desired water temperature stored inside the tank under extreme temperature condition. PIPECO pre-insulated panel could be selected for water storage where there is a need to stabilize the temperature against extreme heat or freezing conditions so to prevent dew formation.

SKID BASE SPECIFICATIONS

Skid Base Specifications for GRP sectional water tank

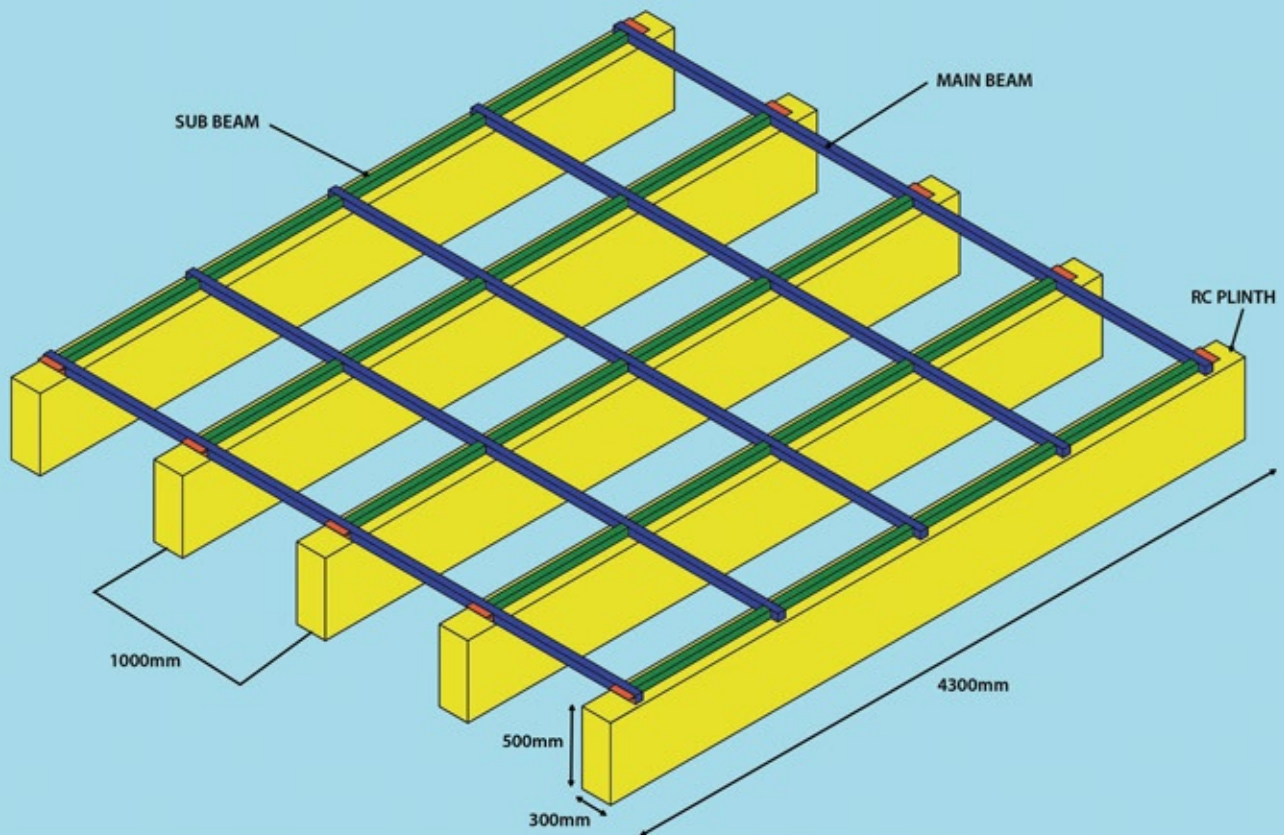

* 4m x 4m foot print skid base illustration

| Tank Height | Main Beam | Sub Beam | Concrete Plinth Distance |
|-------------|---|--|--------------------------|
| 1.0m | not provided | not provided | 1000mm c/c |
| 1.5m | Hollow Section 50mm x 50mm x 3mm | Hollow Section 50mm x 50mm x 3mm | 1000mm c/c |
| 2.0m | Hollow Section 50mm x 50mm x 3mm | Hollow Section 50mm x 50mm x 3mm | 1000mm c/c |
| 2.5m | Hollow Section 50mm x 50mm x 3mm | Hollow Section 50mm x 50mm x 3mm | 1000mm c/c |
| 3.0m | Hollow Section 50mm x 50mm x 3mm | Hollow Section 50mm x 50mm x 3mm | 1000mm c/c |
| 3.5m | C-channel 150mm x 75mm or I Beam 150mm x 100mm | Angle Bar 6mm x 75mm x 75mm or C-channel 50mm x 100mm | 1000mm c/c |
| 4.0m | C-channel 150mm x 75mm or I Beam 150mm x 100mm | C-channel 50mm x 100mm | 1000mm c/c |

*PIPECO reserves the right to provide alternate skid base designs

PIPECO recommends an ideal concrete plinth size of 300mm (W) x 500mm (H), with maximum variance in height of not more than 2mm

GRP SECTIONAL WATER TANK

Overview of internal structural support for GRP sectional water tank

PIPECO GRP sectional water tank is constructed with bottom, side and top panels, completes with external and internal structural reinforcement and necessary tank accessories to facilitate water storage

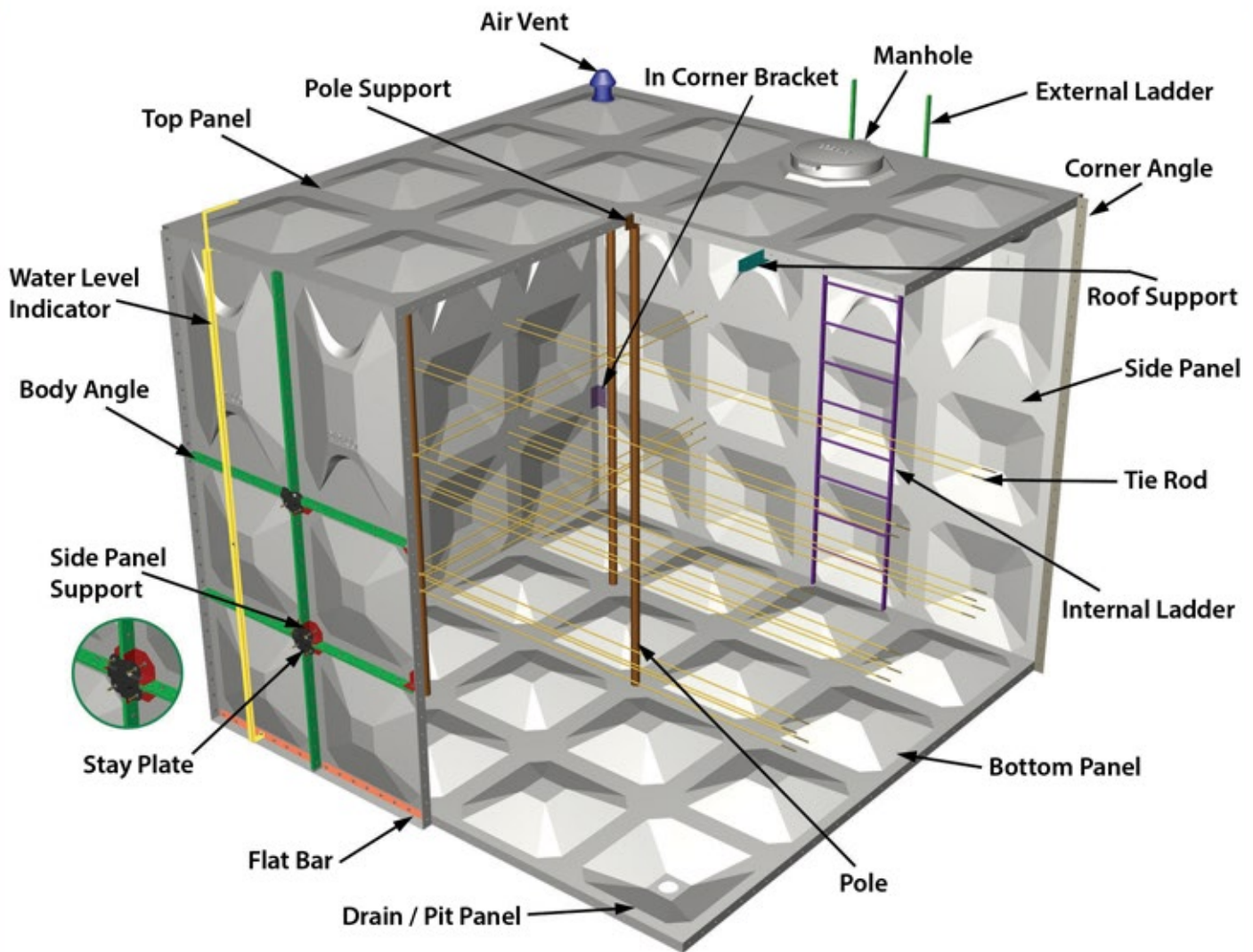

*4m x 4m x 3.5m(H) GRP sectional water tank illustration

| Main Components | External Structural Support | Internal Structural Support | Tank Accessories |
|--|--|--|---|
| Top Panel Side Panel Bottom Panel Drain/Pit Panel | Body Angle Corner Angle Side Panel Support Flat Bar Stay Plate | Pole Pole Support Tie Rod Roof Support In Corner Bracket | Access Manhole Air Vent Water Level Indicator Internal Ladder External Ladder |

GRP EXTERNAL BRACED SECTIONAL WATER TANK

Overview of external structural support for GRP sectional water tank

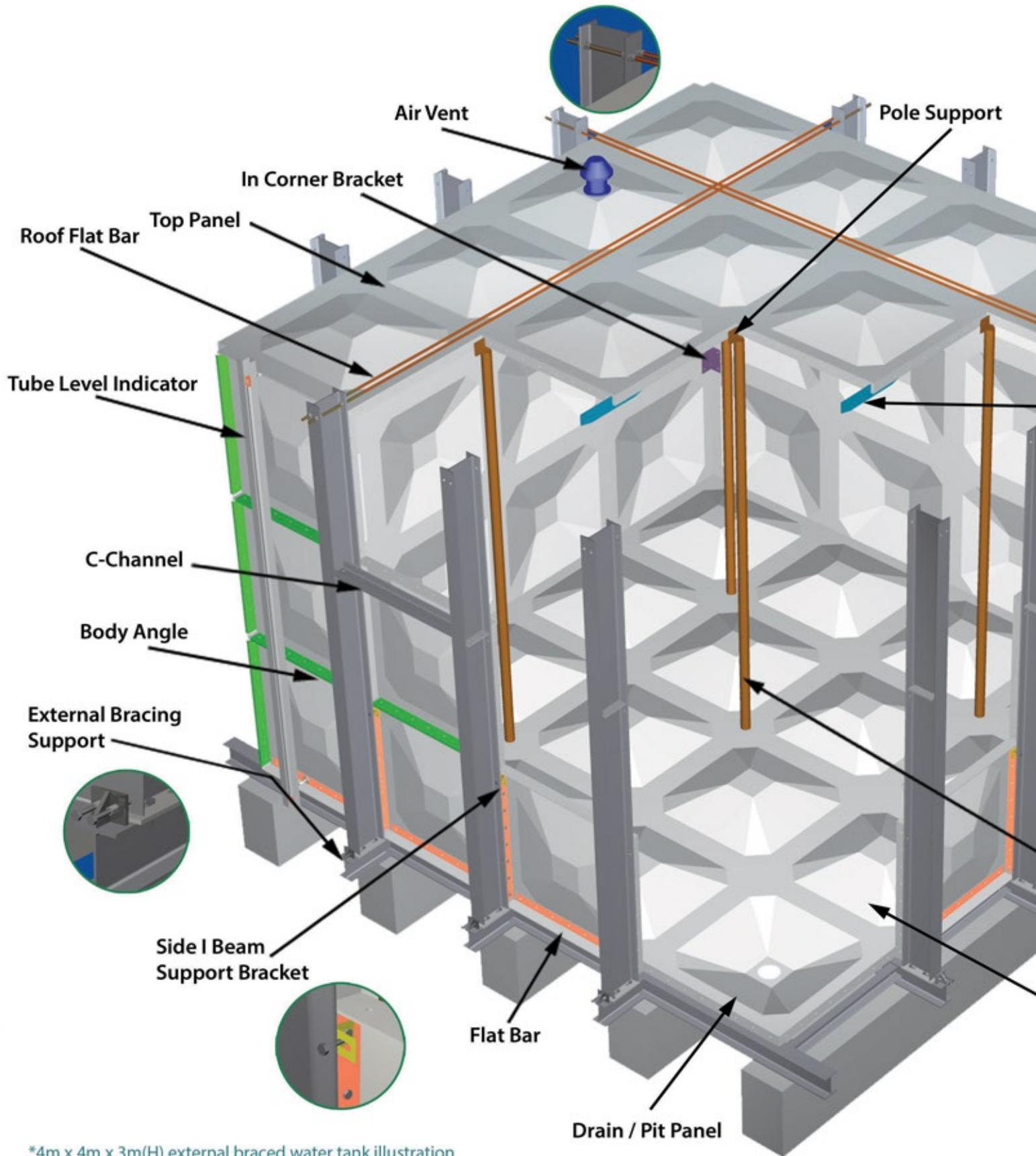

*4m x 4m x 3m(H) external braced water tank illustration

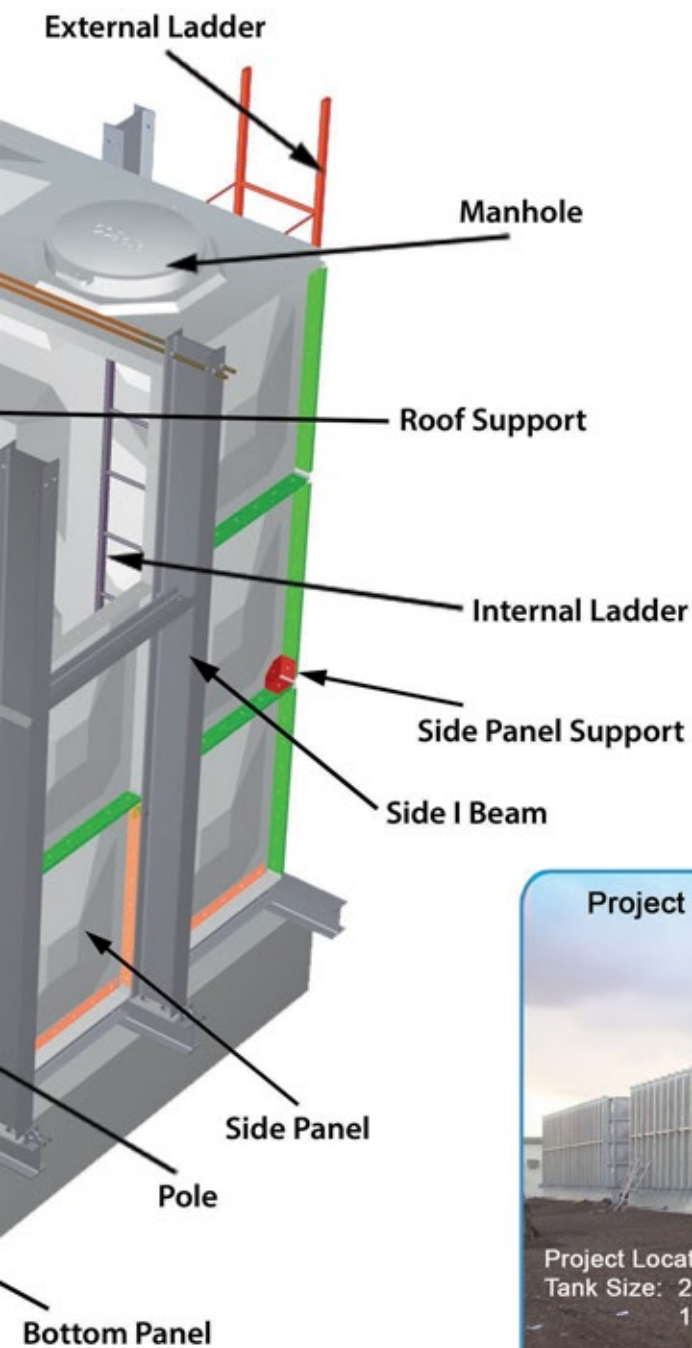

| Main Components | Internal Structural Support |
|--|--|
| <ul style="list-style-type: none"> • Top Panel • Side Panel • Bottom Panel • Drain / Pit Panel | <ul style="list-style-type: none"> • Pole • Pole Support • Roof Support • In Corner Bracket |
| External Structural Support | Tank Accessories |
| <ul style="list-style-type: none"> • Flat Bar • Body Angle • Side Panel Support • C-Channel • Vertical I Beam • Roof Flat Bar • Side I Beam Support Bracket • External Bracing Support | <ul style="list-style-type: none"> • Access Manhole • Internal Ladder • External Ladder • Air Vent • Tube Level Indicator |

Project Name : Camel Training and Swimming Pool in AL-Ain



Project Location: Abu Dhabi
 Tank Size: 20m x 20m x 4m(H) - 2units
 10m x 10m x 4m(H)



PRESSED STEEL SECTIONAL WATER TANK



PRESSED STEEL SECTIONAL WATER TANK

GENERAL SPECIFICATIONS

Standard :

PIPECO pressed steel sectional water tank constructed with hydraulically pressed flanged panels, conform to BS 1564 : 1975 and SS22 : 1979.

Materials :

The steel used in the manufacture of the tank plates, stays and cleats conform to the requirements of BS 4360 : 1972 grade 43A or ISO equivalent

Flanges of Plates :

Tank panels pressed with a combined double flange at an angle of 45 degree and 90 degree to the face of the plate on four sides

Stays and Cleats :

The stays and cleats are made of steel angle bar and steel plate

Bolts, Nuts and Washers:

Hot Dipped Galvanised steel bolts, nuts and washers for internal and external

Jointing Materials :

Non toxic PVC foam to be used for all jointing between tank panel flange

Tank Cover :

Panel type steel cover supported by trusses
600mm x 600mm square manhole and 100mm air-vent supplied as standard for each compartment

Water Level Indicator :

Reverse Reading Pointer Mechanical Type (Cat & Mouse)

Nozzles for Connection :

Short pipe with flange or socket for all pipe connections

Ladder :

Aluminium or HDG Steel ladder for internal and external access

Finish :

Hot Dip Galvanised conform to ISO 1461

Standard Thickness for 1.22m x 1.22m Tank Panel

| Type | 1.22m (H) | 2.44m (H) | 3.66m (H) | 4.88m (H) |
|-----------------|-----------|-----------|-----------|-----------|
| 4th side panels | | | | 5mm |
| 3rd side panels | | | 5mm | 5mm |
| 2nd side panels | | 5mm | 5mm | 5mm |
| 1st side panels | 5mm | 5mm | 5mm | 6mm |
| Bottom panels | 5mm | 5mm | 5mm | 6mm |

Standard Thickness for 1m x 1m Tank Panel

| Type | 1.0m (H) | 2.0m (H) | 3.0m (H) | 4.0m (H) | 5.0m (H) |
|-----------------|----------|----------|----------|----------|----------|
| 5th side panels | | | | | 5mm |
| 4th side panels | | | | 5mm | 5mm |
| 3rd side panels | | | 5mm | 5mm | 5mm |
| 2nd side panels | | 5mm | 5mm | 5mm | 5mm |
| 1st side panels | 5mm | 5mm | 5mm | 5mm | 5mm |
| Bottom panels | 5mm | 5mm | 5mm | 5mm | 5mm |

British Standard Specification for PRESSED STEEL SECTIONAL RECTANGULAR TANK

1. Scope

This British Standard specifies requirement for pressed steel sectional rectangular tanks, working under a pressure not greater than the static head corresponding to the depth of the tanks, built up of pressed steel plates 1220mm square used to contain cold water, hot water, potable liquids, certain oils and chemicals. Tanks may be constructed as follows:

- (a) with external flanges;
- (b) with internal bottom flanges, external side and end flanges.

Two types are specified:

Type 1. With a combined double flange at an angle of 45° and 90° to the plane of the plate on all four sides as illustrated in figure 1. The plates of type 1 tanks are hot pressed complete.

Type 2. With a single flange at an angle of 90° to the plane of the plate on each of two, three or four sides, depending on its position in the tank. Type 2 tanks are cold pressed as illustrated in figure 2, with the flange corners welded.

This standard does not provide for tanks subject to earth or other external pressure other than wind pressure.

NOTE: For an illustration of a typical tank external flanges see figure 8. For approximate weights and full nominal capacities (without freeboard) of open top tanks see tables 1 to 4.

Tanks can also be assembled with all flanges internal with the addition of other components, but because of the difficulty of assembling and maintaining this type of tank they are not preferred.

All tanks can be supplied with open or closed top. Information on erection and supports is also included.

2. References

The titles of the British Standards referred to in this standard are listed on the inside back cover.

3. Information to be supplied with the enquiry and order

The following information, as appropriate, should be supplied by the purchaser with his enquiry or order.

- (a) Type of tank required (clause 1), type of cover (if any), number and position and type of manhole(s), number of divisions if required.
- (b) Capacity required in liters or dimensions in millimeters in multiples of 1220 mm and whether any provision is to be made for future extension and if any level indicators are required.

(c) Limiting conditions, if any, as to space and accessibility for erection, and whether the tank will be erected in a building or exposed to the weather, and the height above ground level it is to be installed.

(d) Nature and density of liquid for which the tank is required. If corrosive, particulars to be given. If water, state whether hard or soft. The rate of filling and emptying the tank, head fluctuations and cycles per day.

(e) Maximum and minimum temperatures and approximate rate of fluctuation and position of heating elements.

(f) Any special requirements as to jointing material and as to internal and external coating or lagging.

NOTE: In the absence of any special requirements one coat of a suitable priming paint will be applied to protect the tank during delivery and erection. A minimum of two further coats should be applied after erection.

(g) Particulars of connections and drilling required and precise location on tank with dimensioned sketches, having regard to possible future requirements.

(h) Whether external access ladders are required and, if so, particulars to be given.

(i) Details of any existing or proposed supporting structure and height of bottom of tank above ground level so that the necessary scaffolding arrangements can be made to comply with statutory safety regulations.

(j) Whether transverse supporting bearers are required and, if so, particulars as to span and end support to be given.

(k) Whether the tank is to be used for other than a stationary application.

(l) Whether inspection will be made by the representative of the purchaser at the works of the manufacturer.

(m) Whether erection is to be carried out by the manufacturer at site; if so, information as to site conditions and accessibility to be given by the purchaser.

4. Working temperatures

For the purpose of this standard cold liquids are defined as those having a temperature not exceeding 38 °C and hot liquids are defined as those having a temperature exceeding 38 °C but less than 100 °C.

In the case of tanks to hold hot liquids, care shall be taken in use to avoid excessive vibration or turbulence. Tanks for temperatures higher than 100 °C should be the subject of mutual arrangement between the purchaser and the manufacturer.

British Standard Specification for PRESSED STEEL SECTIONAL RECTANGULAR TANK

5. Materials

5.1 The steel used in the manufacture of the plates, stays, cleats and pads for connections shall conform to the requirements of BS 4360: 1972 grade 43A or BS 1449: Part 1: 1972 material HR 14.

5.2 Bolts, studs, nuts and washers shall be made from steel complying with the requirements of BS 4190. Bolts and nuts shall be hexagonal, black finish, screwed ISO metric complying with the requirements of BS 4190, where applicable. Washers shall comply with the requirements of BS 4320: 1968 from 'F'.

6. Dimensions of unit plates

The nominal size of unit plates shall be 1200 mm square. The actual overall dimensions depending upon the particular manufacturer of the plates. The size of tanks shall be specified as multiples of the nominal dimension.

7. Thickness of unit plates

7.1 For cold liquids with a density not exceeding 1.0 the nominal thickness of the plate from which the unit plates are pressed shall be not less than:

| | mm |
|---|----|
| Tanks 1220mm in depth: -bottom, sides and ends. | 5 |
| Tanks 2440 mm in depth: -bottom, sides and ends. | 5 |
| Tanks 3660 mm in depth: -bottom, sides and ends. | 5 |
| Tanks 4880 mm in depth: -bottom, and first tier of sides and ends | 6 |
| -second, third and top tiers of sides and ends. | 5 |

7.2 For hot liquids with a density not exceeding 1.0 no plate shall be less than 6 mm in thickness.

7.3 For cold or hot liquids with a density greater than 1.0 the plate thicknesses shall be a matter for mutual arrangement between the purchaser and the manufacturer

8. Permissible stresses

The calculated stress in any stay and attachment and bolts shall comply with the requirements of BS 449, and any allowance that may be required for corrosion shall be added to the calculated thickness.

9. Flanges of plate

Plate shall be pressed with a combined double flange at an angle of 45° and 90° to the face of the plate on all four sides (type 1 figure 1) or a single flange at an angle of 90° to the plate on each of two, three or four sides (type 2 figure 2), the flanges holed according to the respective position of the plate in the tank and free from irregularities.

The width of the flanges shall be not less than 45 mm, the holes for the bolts having a clearance of 1.5 mm in diameter, the bolts having a minimum diameter of 14 mm (M14). The spacing of bolts holes shall not exceed 76.2 mm pitch.

10. Jointing material

The jointing to be used for tanks shall be suitable for the conditions and shall be a matter for mutual agreement between the purchaser and manufacturer. Any jointing used shall be insoluble in the liquid to be stored and, where necessary, shall be non-toxic.

11. Bolts, studs, nuts and washers

Bolts, studs, nuts and washers shall be in accordance with the requirement specified in 5.2. Each flange bolt shall be fitted with one flat washer under the nut and the diameter of the bolts shall be not less than 14 mm (M14).

12. Staying

12.1 The sides and ends of all tanks shall be supported by stays at the junction of two or more plates the stays shall be made from mild steel rolled sections calculated in accordance with clause 7. Stays shall be attached to the plates by bolting to cleats of equal strength bolted to tank plates; stay attachments to cleats and cleats to tank plates shall be calculated taking into account eccentricity of loading. The ends of the stays shall be attached to the cleats or tank plates by bolts.

12.2 Stays shall connect sides to bottom, ends to bottom and/or horizontally sides and sides to ends generally in accordance with figure 8.

13. Connections

13.1 Pads for connections, tapped bosses, screwed flanges or sockets, as may be required by the purchaser, shall be welded to the inside or outside or bolted to the tank plate. Pads shall be drilled, and/or tapped as necessary to suit flanges complying with the requirements of BS4504, or such other standard as specified by the purchaser. Single pads shall be provided for connection on one side of the plate and double pads for connection on both sides of the plate. Tapped sockets shall comply with the requirements specified in BS 1387.

Typical types of welded connections are shown in figures 3 to 7.

British Standard Specification for PRESSED STEEL SECTIONAL RECTANGULAR TANK

14. Welding of connections

Welds for connections shall be made by the metal arc process complying with the requirements of BS 1856 and by means of covered electrodes complying with the requirements of BS 639 : 1972 sections 1 and 2 : grade 1.

15. Supports

All tanks shall effectively supported in accordance with the manufacturer's recommendations and tolerances. Supports shall be provided continuously under each bottom flange in one direction at 1220 mm centers. Tanks with internal bottom flanges can also rest directly on a flat level base. A sand/bitumen bed 50 mm thick is recommended in that case. Where steel joists are used they shall be designed to carry the imposed load with a maximum deflection of one five-hundredth of the span. Attention is drawn to the extra reaction on the supports under the side, end and division plates when the stays of sides, ends and divisions are inclined to the bottom of the tank.

16. Closed top tanks

16.1 Cover framing members shall be designed to withstand superimposed loadings complying with the requirements of BS 449.

16.2 Covers may be flat indoor use and should be pitched or cambered for outdoor use, and jointed to ensure that they are dust and weather proof.

16.3 Covers may be constructed of steel plates or other constructional cladding materials.

16.4 In all cases closed top tanks shall be provided with a manhole of not less than 460 mm diameter clear opening to give access to the inside of the tank and with a suitable vent, filtered if necessary, to the manufacturer's requirements to avoid pressure changes within the tank.

17. Access Ladders

Tanks over 1220mm deep shall be provided with a steel internal access ladder. In covered tanks the ladder shall be adjacent to the manhole.

NOTE. External ladders may be provided required; attention is drawn to BS 4211.

18. Marking

All tanks complying with the requirements of this standard shall be legibly marked as follows.

(a) Manufacturer's name, mark or initial.

(h) The number of this British Standard, i.e. BS 1564.

19. Minimum access

Where tanks with external flanges are to be erected in a confined space it is essential that a clearance of not less than 500 mm shall be provided all round the outside and underneath to facilitate erection.

For access to the top of a closed tank the clearance at the top shall be not less than 750 mm.

NOTE. Allowance should be made for inspection and maintenance including valves or other external fittings.

20. Inspection

20.1 Works inspection. The purchaser or his representative shall have access to the works of the manufacturer at all reasonable times and shall be at liberty to inspect and to reject any material which does not comply with the requirements of this standard. Such inspection shall include verification that the unit plates will mate together and assemble. Where partial or complete assembly is required at the works of the manufacturer, this shall be the subject of specific arrangement between the purchaser and the manufacturer at the time of enquiry and order.

20.2 Site inspection. The purchaser or his representative shall ensure that supports are within the tolerances required by the manufacturer before the commencement of erection.

21. Erection

Erection shall be carried out in accordance with the manufacturer's instructions.

22. Testing

Testing shall be filling the tank with water on site and shall be the subject of specific arrangement between the purchaser and the manufacturer at the time of the enquiry and order. Water for testing shall be supplied by the purchaser.

PRESSED STAINLESS STEEL SECTIONAL WATER TANK

GENERAL SPECIFICATIONS

Standard :

PIPECO pressed stainless steel sectional water tank constructed with hydraulically pressed flanged panels, SS 304 & 316

Materials:

The tank panel, tie rods, stays and cleats are made from Stainless Steel Grade 304 / 316

Flanges of Plates :

Tank panels pressed with a 90 degree panel flange to the face of the plate on four sides

Bolts, Nuts and Washers :

SS 304/ 316 bolts, nuts and washer

Jointing Materials :

Non toxic PVC foam to be used for all jointing between tank panel flange

Tank Cover :

Panel type tank cover supported by trusses
600mm x 600mm square manhole and supplied as standard for each compartment

Water Level Indicator :

Standard : Reversed Reading Mechanical type with Cat and Mouse
Optional : Direct Reading Clear Tube Type

Nozzles for Connection :

Short pipe with flange or socket for all pipe connections

Ladder :

Internal ladder shall be made of SS 304/316 and aluminium for external ladder

Skid Base :

HDG C-Channels

Standard Thickness for 1.22m x 1.22m Tank Panel

| Type | 1.22m (H) | 2.44m (H) | 3.66m (H) | 4.88m (H) |
|-----------------|-----------|-----------|-----------|-----------|
| Top panels | 1.5mm | 1.5mm | 1.5mm | 1.5mm |
| 4th side panels | | | | 2.5mm |
| 3rd side panels | | | 2.5mm | 2.5mm |
| 2nd side panels | | 2.5mm | 3.0mm | 3.0mm |
| 1st side panels | 2.5mm | 2.5mm | 4.0mm | 4.0mm |
| Bottom panels | 2.5mm | 2.5mm | 4.0mm | 4.0mm |

Standard Thickness for 1.0m x 1.0m Tank Panel

| Type | 1.0m (H) | 1.5m (H) | 2.0m (H) | 2.5m(H) | 3.0m (H) | 3.5m (H) | 4.0m (H) |
|-----------------|----------|-------------|-----------|-------------|-----------|-------------|-----------|
| Top panels | 1.5mm | 1.5mm | 1.5mm | 1.5mm | 1.5mm | 1.5mm | 1.5mm |
| 4th side panels | | | | | | | |
| 3rd side panels | | | | | | 2mm(1x1.5m) | 2mm(1x2m) |
| 2nd side panels | | | | 2mm(1x1.5m) | 2mm(1x2m) | 2.5mm | 3.0mm |
| 1st side panels | 2.0mm | 2mm(1x1.5m) | 2mm(1x2m) | 2.5mm | 2.5mm | 3.0mm | 4.0mm |
| Bottom panels | 2.0mm | 2.0mm | 2.0mm | 2.5mm | 3.0mm | 4.0mm | 4.0mm |



**Rafal Tower, Highest Tower in Riyadh,
Saudi Arabia**



Broome Hospital, Australia



Philippines, Union Ajinomoto Makati City



West Africa



U.A.E

HEAD OFFICE & FACTORY

PIPECO TANKS MALAYSIA SDN BHD

Lot 3, Lorong 2/1, Solok Sultan Hishamuddin 1, Kawasan Perusahaan Selat Kelang Utara,
42000 Pelabuhan Klang, Selangor Darul Ehsan, Malaysia.
Tel : +603-3176 3318 Fax : +603-3176 0318 Website: www.pipeco.com.my
E-mail: pipeco@pipeco.com.my ; info@pipeco.com.my

BRANCH OFFICES

AUSTRALIA OFFICE

PIPECO TANKS AUSTRALIA

Melbourne, Australia
E-mail: pipeco.tanks.australia@gmail.com

AFRICA OFFICE

PIPECO AFRICA LLC

United Arab Emirates
Tel: +971 6748 7714 Fax: +971 6745 9877
Mob: +971 50 424 5888

BAHRAIN OFFICE

PIPECO BAHRAIN WLL

Salmabad, Kingdom of Bahrain.
Tel: +973 17 300 426 Fax: +973 17 300 427
E-mail : salesbahrain@pipecotank.com
Website : www.pipecotank.com

INDIA OFFICE

PIPECO INDIA PVT LTD.

Sunkadakatte, Bangalore
Tel : +91 80 23566300
Mob : +91-9844262676/+91-9900799755

QATAR OFFICE

PIPECO TANKS DOHA

Doha, Qatar Tel: +97 444 21 0929 Fax: +97 444 73 0414
Mob: +974 33 657 599
E-mail : salesqatar@pipecotank.com
Website : www.pipecogroup.com

WORLD WIDE DISTRIBUTORS

EUROPE / CARIBBEAN / AFRIQUE FRANCOPHONE

PIPECO TANKS EUROPE

E-mail : frichard@pipecotanks.com
cromier@pipecotanks.com

HONG KONG

TOZEN (HK) LTD

E-mail : avan@tozen.com.hk

JORDAN

SOURCES FOR ENGINEERING SUPPLIES CO.

Tel : 962-6-5525255 Fax : 962-6-5525228
E-mail : alaa.ramadan@sources.com.jo

MYANMAR

HAN SEIN THANT TRADING CO., LTD

E-mail : james.purity@gmail.com

SAUDI ARABIA OFFICE

PIPECO WATER TANKS EST.

Riyadh, Kingdom of Saudi Arabia.
Tel : +9661 478 5467 Fax : +9661 242 6016
E-mail : sales@pipecotanks.com
Website : www.pipecogroup.com

SINGAPORE OFFICE

PIPECO INTERNATIONAL PTE. LTD.

Singapore 416032.
Tel : +65-6745 3773 Fax : +65-6743 2412

SOUTH AFRICA OFFICE

PIPECO TANKS SOUTH AFRICA

Sunderland Ridge, Centurion, South Africa
Mob : +27 83 455 0371 Pieter Huyser
: +27829460026 Husain Alli

TAIWAN OFFICE

PIPECO INTERNATIONAL INDUSTRY CO., LTD

Taipei, Taiwan
Tel : 02-2346-2166 Fax : 02-2346-0559
E-mail : pipeco@pipeco.com.tw

U.A.E OFFICE

PIPECO TANKS AJMAN

PIPECO TANKS ABU DHABI

PIPECO TANKS DUBAI

United Arab Emirates
Tel : +971 6745 9878 Fax : +971 6745 9877
Mob : +971 50 424 5888
E-mail : sales@pipecotank.com
Website : www.pipecotank.com/www.pipecogroup.com

PHILIPINES

FLOWMETRICS INDUSTRIAL SALES INC.

Tel : 632-3543144 Fax : 632-9506436
E-mail : froilanvillareal88@gmail.com

SINGAPORE

PIPELINK BECKHAM PTE. LTD.

Tel : +602-6383 5578 Fax : +602-6383 5580
E-mail : pipelink@singnet.com.sg

SULTANTE OF OMAN

ALANSARI TRADING ENTERPRISE LLC

Tel : +968-2481 0033 Fax : +978-2481 2522
E-mail : contactus@alansarioman.com

VIETNAM

H2L CO., LTD (H2L GROUP)

Tel : +84 8 3852 1179 Fax : +84 8 3852 1145
E-mail : sales@h2lgroup.com